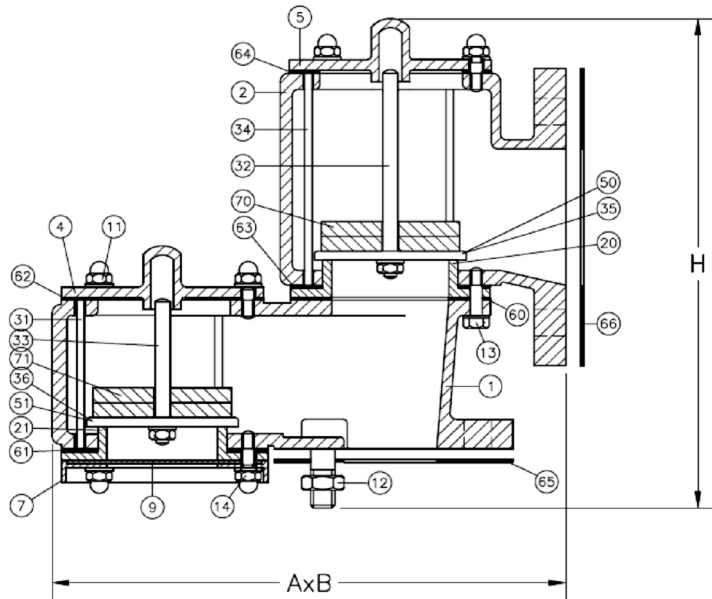

FIG.301.1 BREATHER VALVE, FLANGED DISCHARGE



LUPI AUGUSTO TANK & PIPING PRODUCTS ITALY tel: +39 069370701 fax: +39 0697847415
 e-mail: info@lupiaugusto.com lupiaugusto@gmail.com www.lupiaugusto.com

Technical data	
Design pressure	0.5 Bar
Design temperature	-10/+120 °C
Setting range:	
- pressure	20...1000 mmH2O
- vacuum	-20...-500 mmH2O
Atex certificate	
Factory tested	Body pressure 0.7 Bar dimensional correct setting/s leakage API2521
Size/s	from 2"x3" to 12"x14"
Connections	ANSI 150# FF UNI PN 10/16 FF
External finiture:	aluminium paint as std or epoxy RAL7023



Dimensions & weights				
DN (xx)	Dimensions (mm)			Weight (kg)
	A	B	H	
2"x3"	330	200	290	14
3"x4"	400	229	324	17
4"x6"	460	285	410	36
6"x8"	585	343	471	50
8"x10"	800	406	600	58
10"x12"	960	483	800	82
12"x14"	1050	534	900	106

Materials and product codes for Fig.302.1 Pressure and Vacuum Relief Valves				
Items	Description	Materials		
1	Body	Aluminium	Aluminium	Alum/PTFE lined
2	Conveyor	Aluminium	Aluminium	Alum/PTFE lined
4-5-6	Covers	Aluminium	Aluminium	Alum/PTFE lined
7	Drip ring	Aluminium	Aluminium	Alum/PTFE lined
9-10	Screens	SS304	SS304	SS304
11-13-14	Body screws	SS304	SS304	SS316
12	Flange bolts	Galv.d steel	Galv.d steel	SS304
20-21	Seats	Aluminium/ Teflon® lined	Alum/PTFE lined	Alum/PTFE lined
30-31-34	Guide post	SS304	SS304	SS316
32-33	Pallet stems	SS304	SS304	SS316
35-36	Pallets	SS316	SS316	SS316
50-51	Diaphragms	Teflon® FEP		
60...64	Body gaskets	Flexoid	Asbestos free	PTFE
65-66	Flange gaskets	Flexoid	Asbestos free	PTFE
70-71	Setting weights	Carbon Steel	SS304	SS304
Product code with ANSI flange/s		302.1.xx.101	302.1.xx.103	302.1.xx.105
Product code with UNI flange/s		302.1.xx.102	301.2.xx.104	302.1.xx.106

Neoprene® Viton® Teflon® Kalrez® are DuPont's™ trademarks. DuPont™ is a trademark of DuPont™ and its affiliates