

2

FIG.207.2 MEASURING & SAMPLING HATCH COVER, HANDWHEEL CLOSING AISI316L WELDING END

LUPI AUGUSTO TANK & PIPING PRODUCTS ITALY phone: +39 069370701 fax: +39 0697847415

e-mail: lupiaugusto@gmail.com web-site : www.lupiaugusto.com

Technical data	
Design pressure	<0.5 Bar
Design temperature	-20/120 °C
Operating pressure	<0.5 Bar
Operating temperature	-20/120 °C
Standard features	handwheel closing
Special features	padlock
Sizes	6" and 8"
Ex certificate	
Factory tested	dimensional and air-tight at 0.5 Bar
Connection	Welding end
External finiture:	Pickled

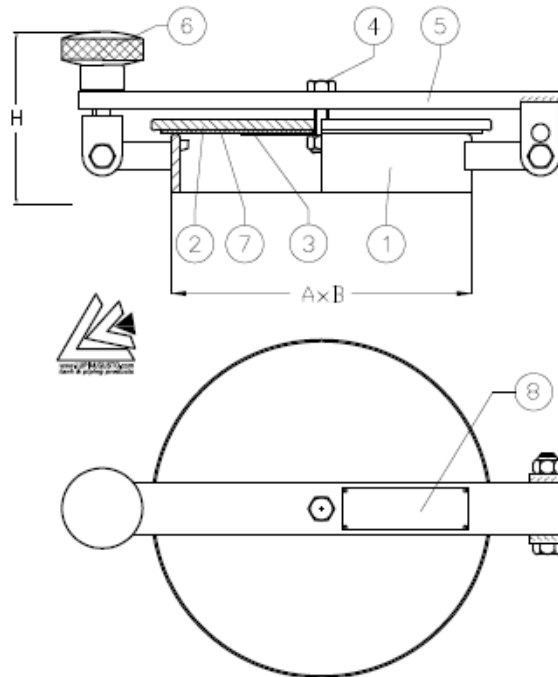

Dimensions and weights				
DN (xx)	Dimensions (mm)			Weight (kg)
	A	B	H	
6"	170	350	150	12
8"	220	400	150	16

Materials and product codes for Fig.207.2 HATCH COVER, welding end		
Items	Description	Materials of construction
1	Body	SS316L
2	Cover	SS316L
3	Retaining disc	SS316L
4	Screw	SS316
5	Lever	SS304
6	Handwheel	SS304/PVC
7	Insert	Neoprene® Viton® Teflon®
8	Label	SS304
Product code, welding end		207.2.xx.101

Neoprene® Viton® Teflon® Kalrez® are DuPont's™ trademarks. DuPont is a trademark of DuPont and its affiliates