

2

FIG.201.1 MEASURING & SAMPLING HATCH COVER, FLANGED



LUPI AUGUSTO TANK & PIPING PRODUCTS ITALY phone: +39 069370701 fax: +39 0697847415

e-mail: lupiaugusto@gmail.com web-site : www.lupiaugusto.com

Technical data	
Design pressure	<0.5 Bar
Design temperature	-20/80 °C
Operating pressure	50 mmH ₂ O
Operating temperature	-20/80 °C
Standard features	safety foot pedal
Special features	self closing or padlock
Sizes	6" and 8"
Ex certificate	
Factory tested	dimensional and air-tight at 50 mmH ₂ O
Connection	flanged Ansi 150# FF or UNI PN10/16
External finiture:	aluminium paint or epoxy RAL7023

Dimensions and weights				
DN (xx)	Dimensions (mm)			Weight (kg)
	A	B	H	
6"	285	350	220	5
8"	345	400	220	6.5

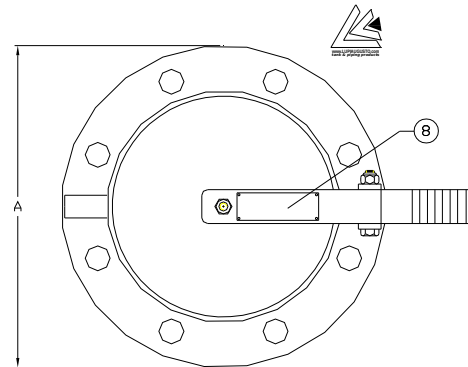
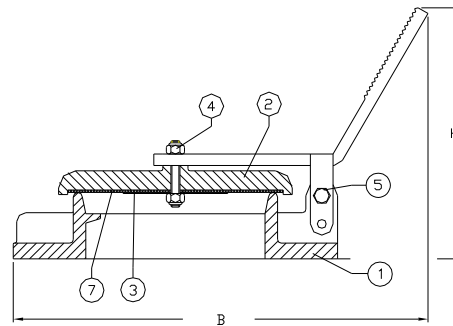

Materials and product codes for Fig.201.1 HATCH COVER

Items	Description	Materials of construction
1	Body	Aluminium
2	Cover	Aluminium
3	Retaining disc	Aluminium
4	Screw	SS304
5	Lever	Galvanized steel
7	Insert	Neoprene® Viton® Teflon®
8	Label	SS304/PVC
Product code with Ansi flanges		201.1.xx.101
Product code with UNI flanges		201.1.xx.102

Neoprene® Viton® Teflon® Kalrez® are DuPont's™ trademarks. DuPont is a trademark of DuPont and its affiliate